

fi-65F Image Scanner

Getting Started

Thank you for purchasing our image scanner. This manual describes the preparation required to use this product. Follow the procedures in this manual. Make sure to read the attached "Safety Precautions" manual before using the scanner. For details about scanner functions and features, basic operation, daily care and troubleshooting, refer to the Operator's Guide (PDF). The Operator's Guide can be displayed by selecting [Browse manual] → [Operator's Guide (PDF)] in the Setup DVD-ROM.

Microsoft product screenshots in this manual are reprinted with permission from Microsoft Corporation.

ISIS is a trademark of Open Text.

Intel, Pentium, and Intel Core are trademarks of Intel Corporation or its subsidiaries in the U.S. and/or other countries.

PaperStream is a registered trademark of PFU Limited in Japan.

Other company names and product names are the registered trademarks or trademarks of the respective companies.

March 2022

© PFU Limited 2013-2022

Checking the Components

Make sure that all items shown below are included in the package. If any other packaging is provided, make sure to keep it as well. The components must be handled with care.

The box and packaging materials are required for storage and transportation of the scanner. Do not throw them away. If anything is missing or damaged, contact your FUJITSU scanner dealer or an authorized FUJITSU scanner service provider.



Scanner (×1)

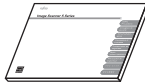

Safety Precautions (×1)

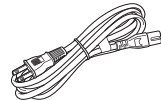

AC cable (×1)

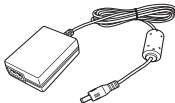

AC adapter (×1)



USB bus power cable (×1)



USB cable (×1)





Setup DVD-ROM (×1)

Safety Information

The attached Safety Precautions manual contains important information about the safe and correct use of this product. Make sure that you read and understand it before using the scanner.

Symbols Used in This Manual

The following symbols are used in this manual.

Symbol	Description
	This indication alerts operators of an operation that, if not strictly observed, may result in severe injury or death.
	This indication alerts operators of an operation that, if not strictly observed, may result in safety hazards to personnel or damage to the product.

Removing the Protective Packaging

The scanner is secured with orange protective tape. Peel off the tape before using the scanner.

Installing the Software

Bundled Software

The following software are bundled with the scanner:

- **PaperStream IP (TWAIN)**
Conforms to the TWAIN standard. Used when you operate the scanner using TWAIN-compliant 32-bit applications.
- **PaperStream IP (TWAIN x64)**
Conforms to the TWAIN standard. Used when you operate the scanner using TWAIN-compliant 64-bit applications.
Can be installed on 64-bit operating systems.
- **PaperStream IP (ISIS) for fi-60F/fi-65F**
Conforms to the ISIS standard. Used when you operate the scanner using ISIS-compliant applications.

- **Software Operation Panel**
View the scanner information and configure various settings such as the operation of the scanner. Installed together with PaperStream IP (TWAIN), PaperStream IP (TWAIN x64), or PaperStream IP (ISIS) for fi-60F/fi-65F.
- **PaperStream ClickScan**
A 32-bit image scanning application which supports PaperStream IP (TWAIN).
Scanning can be performed via simple settings and operations.
This program starts automatically when you log in to your computer and resides in the notification area located at the far right of the task bar.
For details, refer to the PaperStream ClickScan Help.
- **PaperStream Capture**
A 32-bit image scanning application which supports both PaperStream IP (TWAIN) and PaperStream IP (ISIS) for fi-60F/fi-65F. By defining scan settings as document profiles, you can customize the settings according to your preference.
- **PaperStream Capture Pro (EVALUATION)**
A 32-bit image scanning application which supports PaperStream IP (TWAIN). It is the trial version of PaperStream Capture Pro.
To use the full version, purchase and activate a license.
In addition to the functions in PaperStream Capture, PaperStream Capture Pro also allows you to perform multistation operations and advanced meta data settings.
For details, refer to the PaperStream Capture User's Guide.
- **Manual**
Includes Safety Precautions, Getting Started, and Operator's Guide.
- **Scanner Central Admin Agent**
Used to centralize the management of multiple scanners, by allowing you to apply firmware updates simultaneously, monitor the operating status, and check the scanner information.
Note that required applications will differ depending on the form of operation.
For details, refer to the Scanner Central Admin User's Guide.

● **fi Series Online Update**

An application that checks for the software updates for fi Series, and runs the updates.

*1: The software operates as a desktop application.

*2: Required disk space varies according to the file size of the scanned images.

System Requirements

The system requirements are as follows.

Operating system	<ul style="list-style-type: none"> ● Windows Server® 2008 R2 Standard (64-bit) ● Windows® 7 Professional (32-bit/64-bit) ● Windows® 7 Enterprise (32-bit/64-bit) ● Windows Server® 2012 Standard (64-bit) (*1) ● Windows Server® 2012 R2 Standard (64-bit) (*1) ● Windows® 8.1 (32-bit/64-bit) (*1) ● Windows® 8.1 Pro (32-bit/64-bit) (*1) ● Windows® 8.1 Enterprise (32-bit/64-bit) (*1) ● Windows® 10 Home (32-bit/64-bit) (*1) ● Windows® 10 Pro (32-bit/64-bit) (*1) ● Windows® 10 Enterprise (32-bit/64-bit) (*1) ● Windows® 10 Education (32-bit/64-bit) (*1) ● Windows Server® 2016 Standard (64-bit) (*1) ● Windows Server® 2019 Standard (64-bit) (*1) ● Windows Server® 2022 Standard (64-bit) (*1) ● Windows® 11 Home (64-bit) (*1) ● Windows® 11 Pro (64-bit) (*1) ● Windows® 11 Enterprise (64-bit) (*1) ● Windows® 11 Education (64-bit) (*1)
CPU	Intel® Pentium® 4 1.8 GHz or higher (Recommended: Intel® Core™ i5 2.5 GHz or higher, excluding mobile processors)
Memory	1 GB or more (Recommended: 4 GB or more)
Hard disk drive	5,400 rpm or more (Recommended: 7,200 rpm or more)
Display resolution	1,024 × 768 pixels or more, 65,536 colors or more
Hard disk space	11 GB or more of free hard disk space (*2)
DVD drive	Required for installing the software
Interface	USB 2.0/1.1

ATTENTION

- If the system requirements above are not satisfied, the scanner may not operate.
- Scanning speed will slow down in the following cases:
 - The CPU or the memory does not meet the required specifications
 - The version of the USB port or the USB hub is USB 1.1

HINT

The screenshots used in this manual are of Windows® 7. The actual windows and operations may differ depending on the operating system. Where there is no distinction between the different versions of the operating system shown in the table of system requirements, the general term Windows® is used.

Installing the Bundled Software

Install the bundled software from the Setup DVD-ROM in the following procedure. Note that there are two ways to install the bundled software: select [Installation (Recommended)] to install all the software required to operate the scanner, or [Installation (Custom)] to select and install one software at a time.

ATTENTION

If an old version of the software is installed already, uninstall it first. For details about the uninstallation procedures, refer to "A.4 Uninstalling the Software" in the Operator's Guide.

■ Installation (Recommended)

The following software are installed:

- PaperStream IP (TWAIN)
- Software Operation Panel
- PaperStream ClickScan
- PaperStream Capture
- Manual
- fi Series Online Update

1. Turn on the computer and log onto Windows® as a user with Administrator privileges.

- Insert the Setup DVD-ROM into the DVD drive.

⇒ The [fi Series Setup] screen appears.

HINT

If the [fi Series Setup] screen does not appear, double-click "Setup.exe" in the Setup DVD-ROM via Windows Explorer or [Computer].

- Click the scanner model name to be used (if the window for selecting a model name is displayed).

- Click the [Installation (Recommended)] button.

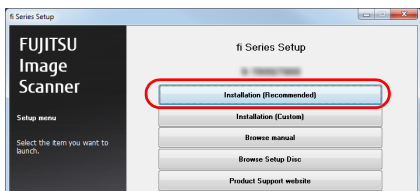

- Follow the instructions on the screen to proceed with the installation.

■ Installation (Custom)

- Perform steps 1. to 3. in "Installation (Recommended) (page 3)".

- Click the [Installation (Custom)] button.

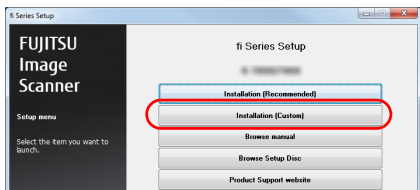

- Select the check box for the software to install and click the [Next] button.

- Follow the instructions on the screen to proceed with the installation.

Installing the Scanner

Install the scanner in the following procedure.

- Place the scanner at its installation site.

ATTENTION

Carry the scanner by supporting it from the bottom.

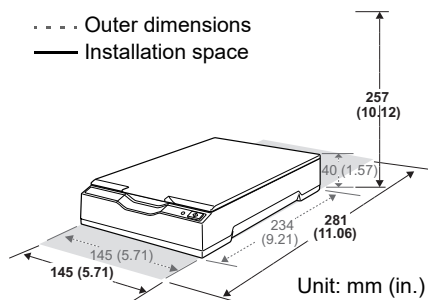

- Unlock the transport lock switch.

There is a carrier unit inside the flatbed which is fixed in place to prevent damage during transportation.

Slide the transport lock switch on the back.

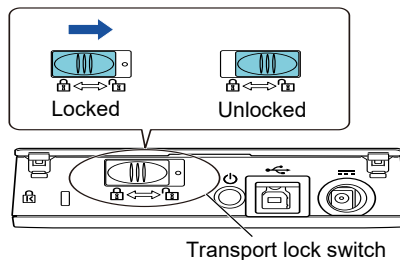

- Select the check box for the software to install and click the [Next] button.

- Follow the instructions on the screen to proceed with the installation.

Connecting the Cables

Connect each cable in the following procedure.

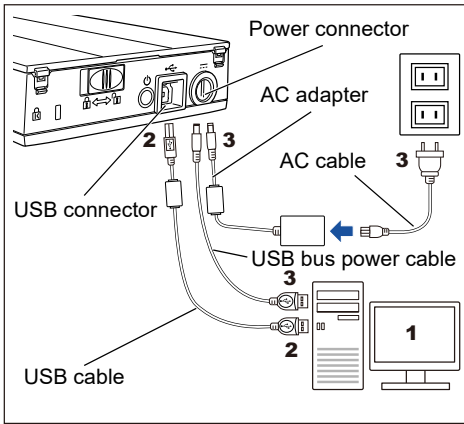

Only use the supplied AC adapter. Not doing so may cause the scanner to malfunction. Furthermore, do not use the supplied AC adaptor for other products.

1. Confirm that the computer is turned off.
2. Connect the USB cable to the USB connector of the scanner and USB port of the computer.

ATTENTION

- Use the supplied USB cable.
- When you use a USB hub, a USB 2.0 certified hub is recommended. If the scanner that is connected to the USB hub does not operate properly, connect the USB cable to the USB port of the computer directly.
- If you connect the scanner with USB 2.0, it is required that the USB port be compliant with USB 2.0. The scanning speed slows down when you connect the scanner with USB 1.1.
- Connect it with the USB mark facing up.

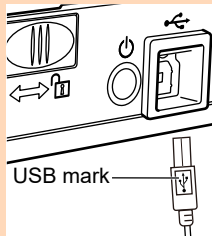

3. Connect the power cable or USB bus power cable.

- For the power cable connection
The AC cable and AC adapter connected to each other are collectively called the "power cable".
Connect the power cable to the power connector of the scanner, and plug the other end into an AC outlet.
- For the USB bus power cable
Connect the USB bus power cable to the power connector of the scanner and to the USB port of the computer.



Only use the power cable or USB bus power cable that is supplied with the scanner.
Doing the following may cause an electric shock or the scanner to malfunction:

- Using a power cable or USB bus power cable that is not supplied with the scanner.
- Using the supplied power cable or USB bus power cable with other products.

Test-Scan

Follow the procedure described below to check that documents can be scanned correctly by using PaperStream Capture and PaperStream IP (TWAIN).

1. Turn on the computer.
⇒ The scanner is turned on, and the power LED lights in green.

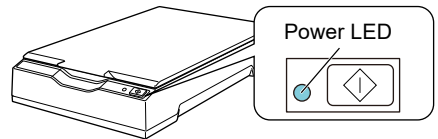

ATTENTION

If the power LED does not light in green, refer to "Chapter 6 Troubleshooting" in the Operator's Guide.

⇒ The scanner is automatically recognized by the computer.

HINT

When the [Found New Hardware] dialog box appears, click [Locate and install driver software (recommended)] and then follow the instructions on the screen to proceed with the installation.

2. Place a document on the scanner.

1. Open the document cover.

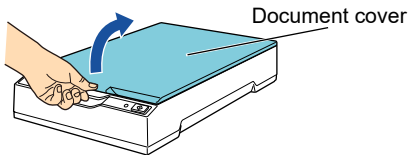

2. Place the document on the document bed.
Place the document face-down to align its top left-hand corner with the reference point.

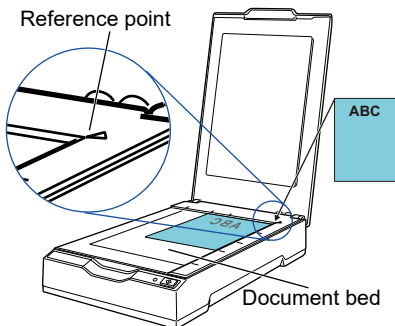

3. Gently close the document cover.

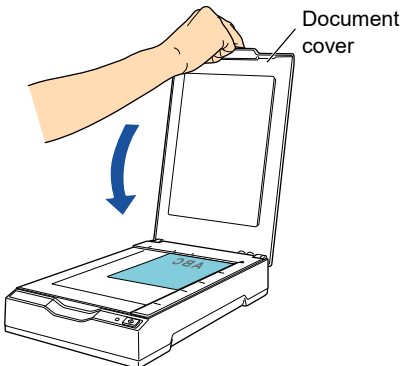

3. Start up PaperStream Capture.

- Windows Server® 2008 R2/Windows® 7
Select the [Start] menu → [All Programs] → [PaperStream Capture] → [PaperStream Capture].
- Windows Server® 2012
Right-click the Start screen, select [All apps] on the app bar, and then select [PaperStream Capture] under [PaperStream Capture].
- Windows Server® 2012 R2/Windows® 8.1
Click [↓] on the lower left side of the Start screen, and then select [PaperStream Capture] under [PaperStream Capture]. To display [↓], move the mouse cursor.
- Windows® 10/Windows Server® 2016/Windows Server® 2019/Windows Server® 2022
Select the [Start] menu → [PaperStream Capture] → [PaperStream Capture].
- Windows® 11
Select the [Start] menu → [All apps] → [PaperStream Capture] → [PaperStream Capture].

4. Click [Scan] in the menu area.

5. Click one of the three types of document profiles that are prepared beforehand.

Below is an example of when the document profile [Black and White] is clicked.

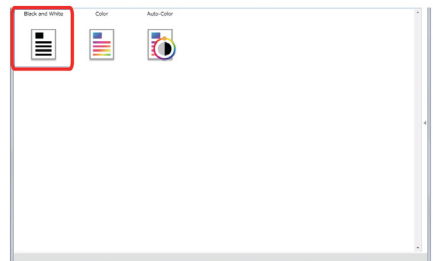

⇒ The document is scanned, and the scanned image is displayed.



ATTENTION

If a problem occurs, refer to "Chapter 6 Troubleshooting" in the Operator's Guide.

For details about other scanning features, refer to "Chapter 4 Various Ways to Scan" in the Operator's Guide.

Contact for Inquiries

Refer to the contact list on the following web page:
<https://imagescanner.fujitsu.com/r/ctl/>

- Image Scanner fi Series

For other inquiries regarding the scanner, refer to the following web page:

<https://www.fujitsu.com/global/support/products/computing/peripheral/scanners/fi/>

If the solution to your problem cannot be found on the above web page, refer to the contact information for your Fujitsu office on the following web page:

<https://www.fujitsu.com/global/about/resources/shop/computing/peripheral/scanners/index.html>

Contact for Purchasing Consumables or Cleaning Materials

<https://imagescanner.fujitsu.com/r/ctl/>

Notice

- Copying of the contents of this document in whole or in part and copying of the scanner application is prohibited under the copyright law.
- The contents of this document are subject to change without notice.