

ScanSnap N1800 Network Scanner

Getting Started

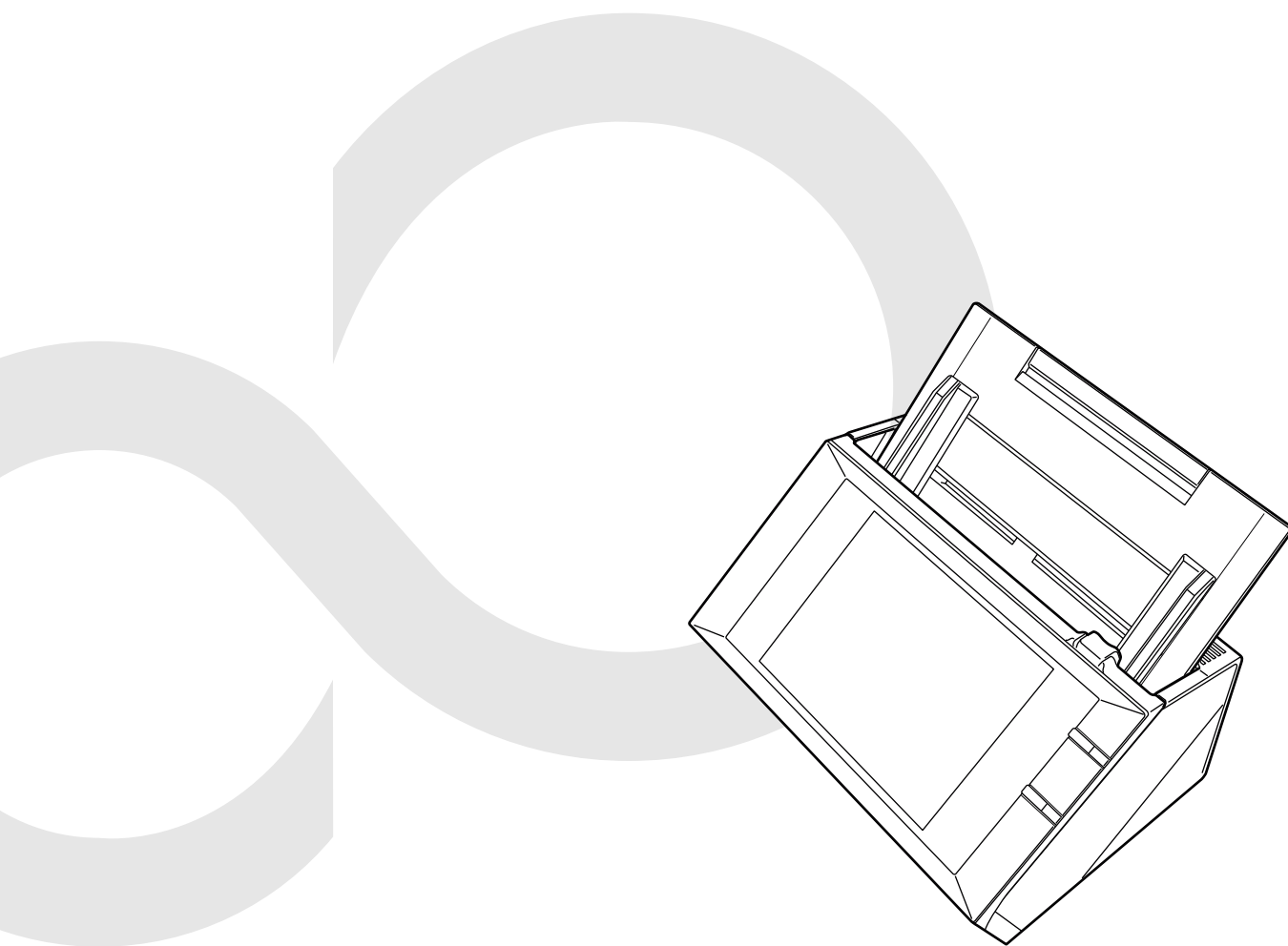

Contents

Introduction	3
■ Manuals	3
■ About This Manual	3
■ Warning Indications Used in This Document	4
■ For Safe Use	4
■ Precautions	6
■ Disclaimer of Liability	7
■ Regulatory Information	7
■ Maintenance	8
Chapter 1 Before Using the Scanner	9
1.1 From Arrival through Operation	9
1.2 Checking the Components	9
1.3 Part Names	10
■ Front view	10
■ Rear view	10
Chapter 2 Setting up the Scanner	11
2.1 Removing the Protective Packaging	11
2.2 Connecting the Scanner	11
Chapter 3 Configuring Scanner Basic Settings	12
Chapter 4 Checking the Network Connection	16
Chapter 5 Downloading the Manual	17
Appendix A Troubleshooting	18
A.1 Network Connection Troubleshooting	18
■ Checking Basic Network Operation with a Ping Test	18
■ Failure to Connect to a Server Using Its IP Address	19
■ Failure to Connect to a Server Using Its Host Name or FQDN	20
■ Failure to Access the Scanner Using a Web Browser, Admin Tool, or Central Admin Server	20
A.2 Power Troubleshooting	22
A.3 Login Troubleshooting	22
A.4 Contact for Inquiries	22
■ Contact for purchasing the Consumable, Cleaning Materials	22
Copyright	23

Introduction

Thank you for purchasing the ScanSnap N1800 Network Scanner.

The ScanSnap N1800 is a network image scanner. This easy-to-operate scanner facilitates the optimal flow of office work for the workgroup communicating via the network.

Trademarks

Microsoft, Windows, Windows Vista, Windows Server, and Internet Explorer are either registered trademarks or trademarks of Microsoft Corporation in the United States and/or other countries.

Adobe, the Adobe logo, Acrobat, and Reader are either registered trademarks or trade names of Adobe Systems Incorporated in the United States and/or other countries. ScanSnap and the ScanSnap logo are registered trademarks or trademarks of PFU LIMITED in Japan. Other company names and product names are the registered trademarks or trademarks of the respective companies.

Manufacturer

PFU LIMITED
International Sales Dept., Imaging Business Division,
Products Group Solid Square East Tower,
580 Horikawa-cho, Saiwai-ku, Kawasaki-shi
Kanagawa 212-8563, Japan
Phone: (81-44) 540-4538

© PFU LIMITED 2010-2013

■ Manuals

Types of Manuals

The following manuals are prepared for the ScanSnap N1800. Read them as needed.

Manual	Description
ScanSnap N1800 Network Scanner Getting Started (This Manual) (paper)	Provides useful and detailed information on the scanner setup and cable connections. Read this manual first. Referred to as "Getting Started" in this manual.
ScanSnap N1800 Network Scanner Operator's Guide (PDF)	Contains further information about scanner settings, scanner administration, and scanner operations, and may be used as a general reference. Referred to as "Operator's Guide" in this manual.

Manual	Description
ScanSnap N1800 Help (HTML)	Provides information about items on the windows, and descriptions and actions to take for the messages. Read it as needed.
Scanner Central Admin User's Guide (PDF)	Provides information about scanner central management operations and settings. Read it as needed.

Accessing the Manuals

- The manuals can be accessed by downloading them from the scanner.
For more details on how to download the Operator's Guide, refer to "Chapter 5 Downloading the Manual" (page 17).
- When the [Help] button is available on the window or dialog box that is displayed during the operation, you can open Help by clicking it.

On the LCD touch panel,  is displayed as a Help button.

■ About This Manual

Arrow Symbols in This Manual

Right-arrow symbols (→) are used to connect icons or menu options you should select in succession.

Example: Select the [Start] menu → [Computer].

Screen Examples in This Manual

Screenshots in this manual are used according to guidelines provided by Microsoft Corporation.

The screen examples in this manual are subject to change without notice in the interest of product improvement.

The screen examples used in this manual are of Windows Vista.

The actual windows and operations may differ depending on the operating system. If the actual screen differs from the screen examples in this manual, operate by following the actual displayed screen.

For Windows Server 2012/Windows 8 Users

To start applications for this product or display Control Panel, use the All apps screen.

The All apps screen is displayed by following the procedure below.

1. Right-click the Start screen.
2. Click [All apps] on the app bar.
Example: Windows 8 screen

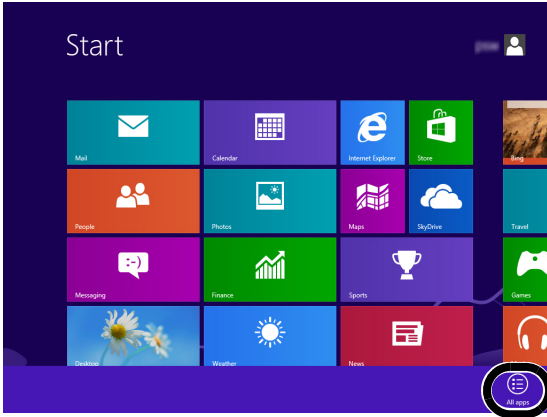

Abbreviations Used in This Manual

The following abbreviations are used in this manual:

Abbreviation Used	Name
Windows XP	Windows® XP Home Edition operating system Windows® XP Professional operating system Windows® XP Professional x64 Edition operating system
Windows Vista	Windows Vista® Home Basic operating system (32/64-bit) Windows Vista® Home Premium operating system (32/64-bit) Windows Vista® Business operating system (32/64-bit) Windows Vista® Enterprise operating system (32/64-bit) Windows Vista® Ultimate operating system (32/64-bit)
Windows 8	Windows® 8 operating system (32/64-bit) Windows® 8 Pro operating system (32/64-bit) Windows® 8 Enterprise operating system (32/64-bit)
Windows Server 2012	Windows Server® 2012 Standard (64-bit)
Internet Explorer	Microsoft® Internet Explorer® Windows® Internet Explorer®
Adobe Reader	Adobe® Reader®
Scanner	ScanSnap N1800
Carrier sheet	ScanSnap Carrier Sheet
Admin Tool	Network Scanner Admin Tool

Abbreviation Used	Name
Central Admin Console	Scanner Central Admin Console
Central Admin Server	Scanner Central Admin Server

Warning Indications Used in This Document

The following indications are used in this document to obviate any chance of accident or damage to you and/or this product.



This indication alerts operators to an operation that, if not strictly observed, may result in severe injury or death.



This indication alerts operators to an operation that, if not strictly observed, may result in safety hazards to personnel or damage to the product.

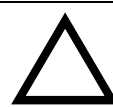

A TRIANGLE symbol indicates that special care and attention is required. The drawing inside the triangle shows the specific caution.



A CIRCLE with a diagonal line inside shows actions which users should not perform. It may also have a drawing inside which shows the specific action that is not allowed.



A white symbol on black background shows instructions which users should follow. It may also include the drawing that shows the specific instruction.

For Safe Use

This manual contains general information regarding safety that must be read before using this product (which includes the scanner and all associated software and manuals). For the safe use of this product, make sure to read the following descriptions.



Keep this manual in a safe place so that it can be easily referred to when using the scanner.

In the following warnings, "power cable" may refer to the AC cable connected to the AC adapter collectively.









⚠ WARNING



	<p>In one of the following situations, immediately turn off the scanner, and disconnect the power cable from the AC outlet. Not doing so may cause a fire or electric shock.</p> <ul style="list-style-type: none"> ● The scanner is damaged for any reason. ● Smoke or heat coming from the scanner is detected. ● Strange noise or smell is detected. ● Foreign objects (water, liquids, small metal objects, etc.) get inside the scanner. ● Other problems which indicate a scanner failure are detected. <p>Then, contact your FUJITSU scanner dealer or an authorized FUJITSU scanner service provider. Never try fixing such problems by yourself. Doing so is dangerous.</p>
	<p>Do not take apart or modify the scanner as high-voltage components inside the scanner are dangerous.</p> <p>PFU assumes no liability to any damage caused by taking apart the scanner, as doing so is not covered under the warranty.</p>
	<p>The area around the part to which this warning label is affixed can become very hot.</p> <p>To avoid burns, never touch around the area indicated by this label.</p>
	<p>Firmly insert the power cable into the AC outlet. Not doing so may cause a fire or the scanner to malfunction.</p>
	<p>Use the scanner only at the indicated power voltage and current. Do not connect to multiple power strips. Improper power voltage or current might cause a fire or electric shock.</p>
	<p>Use only the power cable provided with the scanner. Do not use any extension cords. Doing so may cause abnormal heat or a fire. Do not use the power cable provided with the scanner for other devices, since this may cause problems such as an equipment failure, or an electric shock.</p>
	<p>Do not install the scanner in the following locations which are subject to high temperature, humidity, less ventilation, or dust. If placed in an area subject to high temperature, the cover may become overheated and deformed, resulting in an electric leakage or fire.</p> <p>Use the scanner in a well-ventilated environment.</p> <ul style="list-style-type: none"> ● A place near heat-radiating devices such as stoves or electric heaters, or flammable items such as volatile inflammable materials or curtain. ● A place such as kitchen where oil smoke may be formed. ● A place such as a bathroom, shower room, or swimming pool where it may easily get wet. ● A place under direct sunlight, in a car under the scorching sun, or near heating apparatus where it may get hot.

	<p>To avoid injuries, do not place the scanner in an area where small children may be able to reach.</p>
	<p>Before moving the scanner, be sure to disconnect any cables connected to it (the power cable, the LAN cable, etc.).</p> <p>Make sure that the floor is free of any obstructions.</p> <p>Moving the scanner with the cable connected to the computer may damage the cable, in turn causing fire, electric shock or injuries.</p>
	<p>Do not touch the power cable with wet hands. Doing so may cause an electric shock.</p>
	<p>When disconnecting the power cable from the AC outlet, make sure to hold the power plug and not the cable.</p> <p>Pulling the cable may damage it, which may cause a fire or electric shock.</p>
	<p>Do not use the power cable if it is damaged. Also, do not insert any cables or power plugs into loose sockets. Doing so may cause a fire or electric shock.</p> <p>Be careful of the following when handling the power cable:</p> <ul style="list-style-type: none"> ● Do not moisten, modify, tie, bundle, or wind the cable. ● Do not place heavy objects on the cable, trap the cable in a doorway, drop or damage the cable in any other way. ● Do not pull or forcibly bend or twist the cable. ● Do not place any metal near to the plug of the power cable. <p>If the power cable is damaged, contact your FUJITSU scanner dealer or an authorized FUJITSU scanner service provider.</p>
	<p>Do not place heavy objects on the scanner or perform other work on top of the scanner. Doing so might cause injuries or an equipment failure.</p>
	<p>Do not use the scanner or AC adapter while it is covered, for example, with a blanket. Doing so may raise the temperature inside and cause a fire.</p>
	<p>To avoid injuries, be careful not to get your accessories (e.g. ties, necklaces) or hair caught inside the scanner.</p>
	<p>Do not touch the heated section such as the bottom of the scanner or AC adapter for a long time. Doing so may cause a low-temperature burn on your skin.</p>
	<p>When the scanner is not going to be used for a long period of time, be sure to disconnect the power cable from the AC outlet. Not doing so may cause a fire or electric shock.</p>

	Do not use any aerosol sprays or alcohol based sprays to clean the scanner. Dust blown up by strong air from the spray may enter the inside of the scanner. This may cause the scanner to fail or malfunction. Sparks, caused by static electricity, generated when blowing off dust and dirt from the outside of the scanner may cause a fire.
	Check the following items once a month: <ul style="list-style-type: none"> ● The power cable is firmly inserted into the AC outlet. ● The power cable is not emitting abnormal heat, or the cable is not rusty or bent. ● Dust is not accumulated on the power cable (especially the plug). If so, wipe off any dust with a soft, dry cloth. ● The power cable does not have any cracks or scratches. <p>If any abnormality is detected, contact your FUJITSU scanner dealer or an authorized FUJITSU scanner service provider.</p>

 CAUTION

	When installing the scanner on a table, make sure that the work surface is flat and stable, and that none of the scanner's parts extend over the table edge, otherwise it may fall over or be pulled off the table and cause injuries.
	Install the scanner away from strong magnetic fields and other sources of electronic noise. Protect the scanner against any static electricity and choose a static-free place to install the scanner. Static electricity can cause the scanner to malfunction.
	If there is an electrical storm, turn off the scanner, and disconnect the power cable from the AC outlet. Then, disconnect any connected cables such as the LAN cable. Not doing so may destroy the scanner, which may damage your property.
	Do not supply the power from the AC outlet where devices requiring high power such as copying machines or paper shredders are connected.
	Do not block the ventilation ports. Blocking the ventilation ports generates heat inside of the scanner, which may result in a fire or scanner failure.
	Do not use the scanner immediately after moving it from a cold place into a warm room. Condensation may occur, which might lead to scanning errors. Let the scanner dry for one or two hours before you use it.
	When handling documents or the Carrier Sheet, be careful not to cut your fingers with them.
	Do not use a damaged Carrier Sheet because it may damage or cause the scanner to malfunction.

	When carrying the scanner outside while it is raining or snowing, pay special attention so the scanner does not get wet.
	When you perform cleaning, make sure that the inside of the scanner is free of any foreign objects, and be careful not to get your hand or the cloth caught on the pick spring (metal part) as a deformed pick spring (metal part) may cause injury.

■ Precautions

READ ALL OF THIS DOCUMENT AND THE OPERATOR'S GUIDE CAREFULLY BEFORE USING THIS SCANNER. IF THIS SCANNER IS NOT USED CORRECTLY, UNEXPECTED INJURY MAY BE CAUSED TO USERS OR BYSTANDERS.

Also, keep this document in a safe place so that it can be easily referred to during use of this scanner.

While all efforts have been made to ensure the accuracy of all information in this document, PFU assumes no liability to any party for any damage caused by errors or omissions or by statements of any kind in this document, its updates or supplements, whether such errors are omissions or statements resulting from negligence, accidents, or any other cause.

PFU further assumes no liability arising from the application or use of any scanner or system described herein; nor any liability for incidental or consequential damages arising from the use of this document. PFU disclaims all warranties regarding the information contained herein, whether expressed, implied, or statutory.

Use of Mercury



Lamp(s) inside the scanner contain mercury and must be recycled or disposed of according to local, state, or federal laws.

To avoid unexpected injuries:

- Do not put the substance contained in the lamp in your mouth as it has mercury.
- Do not breathe the chemical liquid contained in the scanner lamps.
- Do not incinerate, crush, or shred the lamps or scanner parts.

LCD Peculiarities

- The LCD backlight is a fluorescent tube that contains some mercury.
- Be aware that neither of the following is considered a fault.
 - Despite the advanced technologies used to produce the devices TFT color LCD's, the large number of pixels involved means that an occasional (always-on) bright dot or (always-off) dark dot may be visible.
 - The characteristics of the LCD mean that there may be some variation in hue and intensity of colors across the screen.

Replacing Batteries

In order to retain data such as BIOS information, this product has a battery (CMOS RAM battery) on board.



- Do not replace the battery yourself, as there is a risk of explosion if the wrong type is used. Please contact your maintenance engineer in charge when the battery runs low.
- Do not touch the battery. Never install or remove the battery by yourself. Doing so may cause electric shock or static electricity which can damage the device.

Warning Label

The scanner carries the warning label. Do not remove the warning label from the scanner. Avoid staining the label, so that it is clearly visible.

Disclaimer of Liability

Reproducibility of the Scanned Image Data

Confirm that the image data scanned with this product meets your requirements (for example, image reproducibility in size accuracy, fidelity, content, colors). Make sure that there are no missing parts in the scanned image data before disposing of the original document used for scanning.

- Note that when there are sections marked with a highlight pen, the color of the marked section may not be accurately reproduced depending on the color and density, or may result in a different color tone from the original.

Regulatory Information

FCC Declaration

This equipment has been tested and found to comply with the limits for a Class B digital device, pursuant to Part 15 of the FCC Rules. These limits are designed to provide reasonable protection against harmful interference in a residential installation. This equipment generates, uses, and can radiate radio frequency energy and, if not installed and used in accordance with the instruction document, may cause harmful interference to radio communications.

However, there is no guarantee that interference will not occur in a particular installation. If this equipment does cause harmful interference to radio or television reception, which can be determined by turning the equipment off and on, the user is encouraged to try to correct the interference by one or more of the following measures:

- Reorient or relocate the receiving antenna.
- Increase the separation between the equipment and receiver.

- Connect the equipment into an outlet on a circuit different from that to which the receiver is located.
- Consult your dealer or an experienced radio/TV technician

FCC warning: Changes or modifications not expressly approved by the party responsible for compliance could void the user's authority to operate the equipment.

NOTICE The use of a shielded interface cable is required to comply with the Class B limits of Part 15 of FCC rules. The length of the power cable must be 3 meters (10 feet) or less.

Canadian DOC Regulations

This digital apparatus does not exceed the Class B limit for radio noise emissions from digital apparatus set out in the Radio Interference Regulations of the Canadian Department of Communications.

This Class B digital apparatus complies with Canadian ICES-003.

Le présent appareil numérique n'émet pas de parasites radioélectriques dépassant les limites applicables aux appareils numériques de la classe B et prescrites dans le Règlement sur le brouillage radioélectrique dictées par le Ministère des Communications du Canada.

Cet appareil numérique de la classe B est conforme à la norme NMB-003 du Canada.

Bescheinigung des Herstellers/Importeurs

Für den Scanner wird folgendes bescheinigt:

- In Übereinstimmung mit den Bestimmungen der EN45014(CE) funktentstört
- Maschinenlärminformationsverordnung 3. GPSGV: Der höchste Schalldruckpegel beträgt 70 dB (A) oder weniger, gemäß EN ISO 7779.

Dieses Gerät wurde nicht für die Benutzung in unmittelbarer Umgebung starker Lichtquellen (z. B. Projektoren) konzipiert.

ENERGY STAR®

PFU Limited, a Fujitsu company, has determined that this product meets the ENERGY STAR® guidelines for energy efficiency. ENERGY STAR® is a registered trademark of the United States.



Use in High-safety Applications

This product has been designed and manufactured on the assumption that it will be used in office, personal, domestic, regular industrial, and general-purpose applications. It has not been designed and manufactured for use in applications (simply called "high-safety applications" from here on) that directly involve danger to life and health when a high degree of safety is required, for example, in the control of nuclear reactions at nuclear power facilities, automatic flight control of aircraft, air traffic control, operation control in mass-transport systems, medical equipment for sustaining life, and

missile firing control in weapons systems, and when provisionally the safety in question is not ensured. The user should use this product with adopting measures for ensuring safety in such high-safety applications. PFU LIMITED assumes no liability whatsoever for damages arising from use of this product by the user in high-safety applications, and for any claims or compensation for damages by the user or a third party.

■ Maintenance

The user must not perform repairs on the scanner. PFU assumes no liability to any damage caused by taking apart the scanner, as doing so is not covered under the warranty.

Contact your FUJITSU scanner dealer or an authorized FUJITSU scanner service provider to make repairs to the scanner.

For contact information, visit the following web page to find the FUJITSU/PFU office for your country.

<http://imagescanner.fujitsu.com/warranty.html>

Or, refer to the contact list on the last page of this document.

Chapter 1 Before Using the Scanner

1.1 From Arrival through Operation

The following shows the flow from scanner arrival through operation.

This manual provides information about Steps 1 to 5 shown below.

For information about Steps 6 to 9, refer to the manuals downloaded in Step 5.

1	Check package
	⇒ "1.2 Checking the Components" (page 9)
2	Setup scanner
	⇒ "Chapter 2 Setting up the Scanner" (page 11)
3	Configure scanner basic settings
	⇒ "Chapter 3 Configuring Scanner Basic Settings" (page 12)
4	Check network connection
	⇒ "Chapter 4 Checking the Network Connection" (page 16)
5	Download manual
	⇒ "Chapter 5 Downloading the Manual" (page 17)
6	Install Admin Tool
	⇒ Refer to the Operator's Guide.
7	Perform scan test
	⇒ Refer to the Operator's Guide.
8	Configure required settings for scanner use
	⇒ Refer to the Operator's Guide.
9	Operate scanner
	⇒ Refer to the Operator's Guide.

1.2 Checking the Components

Make sure that all items shown below are included in the package. If any other packaging is provided, make sure to store it as well. Make sure to handle the components with care.

If anything is missing or damaged, contact your FUJITSU scanner dealer or an authorized FUJITSU scanner service provider.

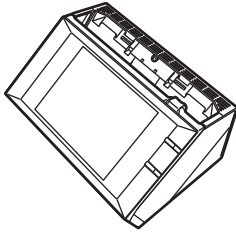
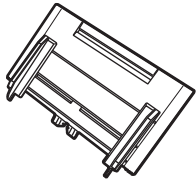
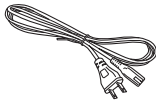
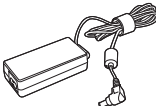
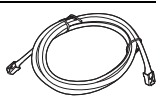
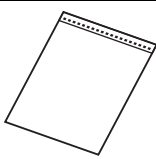
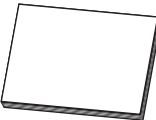
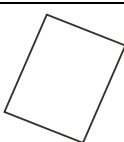
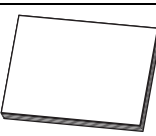
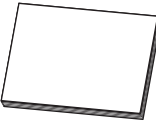
	Scanner
	ADF paper chute
	AC cable
	AC adapter
	LAN cable (straight-through)
	Carrier sheet
	Getting Started (this manual)
	Instruction
	EULA Terms for Microsoft® Windows® XP Embedded and Windows® Embedded Standard
	End-User License Agreement For Network Scanner ScanSnap N1800 Embedded Software

1.3 Part Names

This section explains names of the scanner parts.

■ Front view

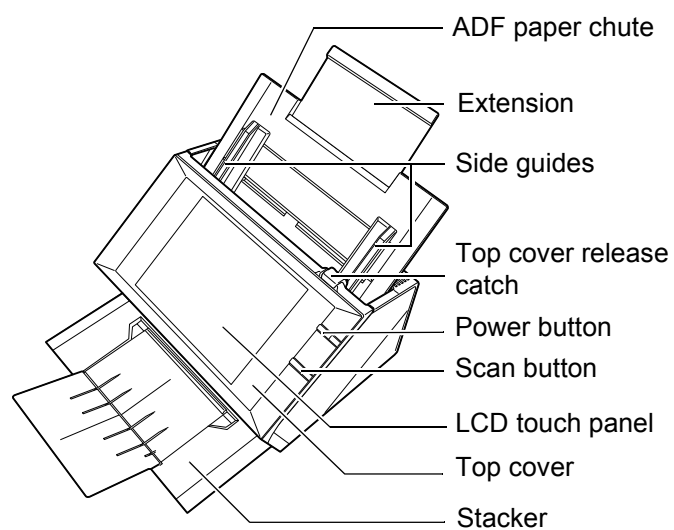

■ Rear view

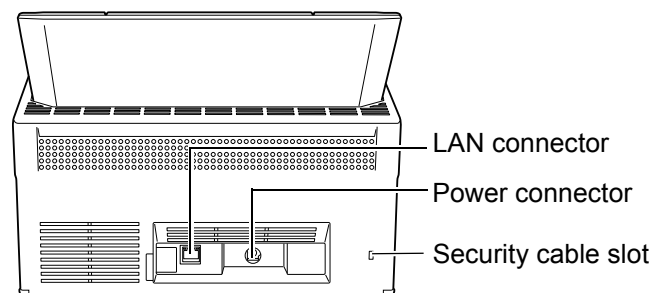

Chapter 2 Setting up the Scanner

2.1 Removing the Protective Packaging

The scanner comes with a protective foam sheet and protective card attached. Follow the procedure described below to remove the protective packaging before using the scanner.

1. Remove the tape and protective foam sheet that covers the LCD touch panel.
2. Pull the top cover release catch to open the top cover, and remove the tape and protective card.

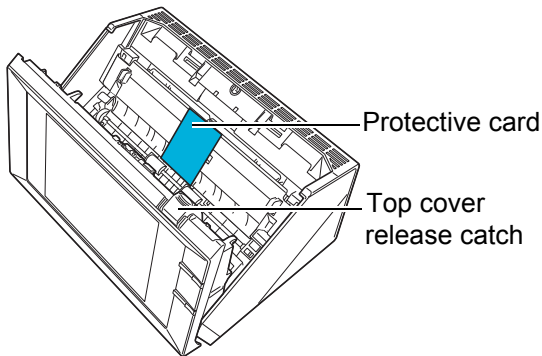

3. Pull the stacker forward, and then remove the tape and protective card.

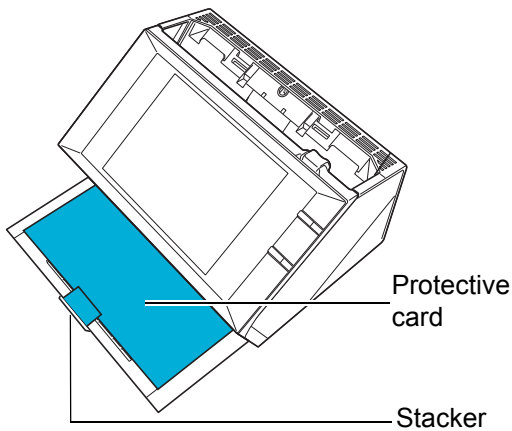

2.2 Connecting the Scanner

1. Place the scanner at its installation site.

ATTENTION

The following space is required to set up the scanner:

- Depth: 700 mm (28 in.)
- Width: 400 mm (16 in.)
- Height: 500 mm (20 in.)

2. Attach the ADF paper chute.

Hold the ADF paper chute with side guides face-up, and insert the tabs into the corresponding slots on the scanner.

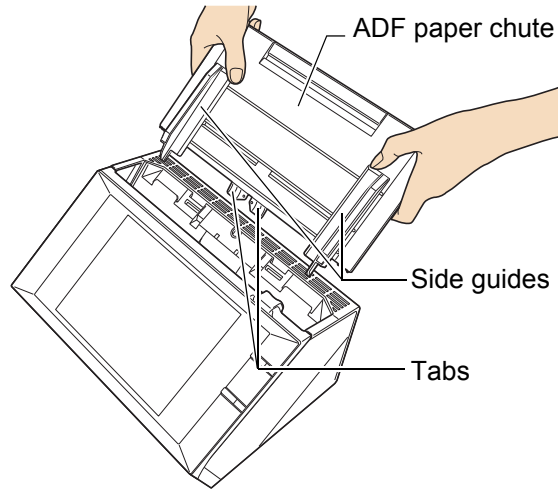

3. Connect the AC cable to the AC adapter (collectively called "power cable").

ATTENTION

Use only the AC adapter and AC cable provided with the scanner.

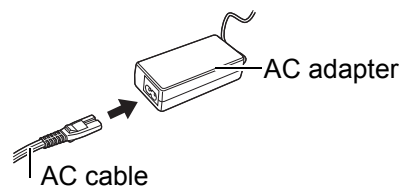

4. Connect the cables to the scanner.

- 1 Connect the power cable to the scanner's power connector.
- 2 Connect the LAN cable to the LAN connector.

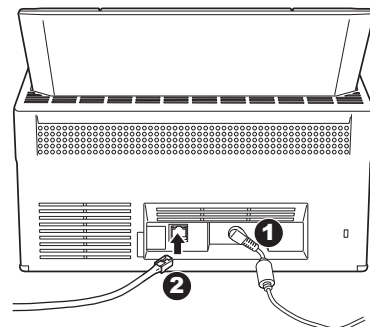

5. Connect the other end of the LAN cable to the network hub.

6. Insert the power cable into an AC outlet.

⇒ The power is connected but the scanner is not yet ready for operation.

Chapter 3 Configuring Scanner Basic Settings



Do not move or shake the scanner when it is turned on. This may damage components in the scanner and cause data to be lost.

When the power button is pressed for the first time after purchase, the window for scanner basic settings appears automatically. The basic settings for using the scanner can be configured with this process.

1. Press the power button on the scanner.

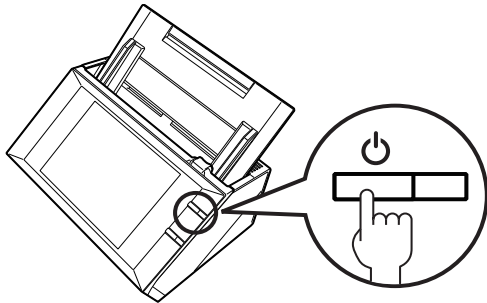

⇒ The [Language Selection] window appears.

2. Select a language, and press the [OK] button.
The default language is "English (US)".



⇒ The confirmation window appears for a scanner restart.

HINT

You can select whether or not to display this window again at the next start up. To display the window again, for "Show this message at next start up?", select [Yes]. To not display this window at next start up, select [No].

To change the setting back to displaying this window at the next start up, login as the administrator, select [System Settings] → [Local Settings] → [Language Selection], and select [Yes] for "Show the "Language Selection" screen at next start up?".

3. Press the [OK] button.

⇒ The scanner is restarted.

When [Yes] is selected for "Show this message at next start up?" on the [Language Selection] window, the [Language Selection] window appears again.

When [No] is selected for "Show this message at next start up?" on the [Language Selection] window, the [Installation Wizard] window appears. Proceed to Step 5.

4. Check the selected language, and press the [OK] button.

⇒ The [Installation Wizard] window appears.

5. Select the items to be specified in the scanner basic settings.

Select the target items to be configured on the [Installation Wizard] window, and press the [Start] button.

Lightly touch the button for the target item.

This section shows an example with all items selected.

ATTENTION

Do not use a pen or other hard object on the LCD touch panel. The LCD touch panel may be damaged.

HINT

For details about setting items, refer to Help.



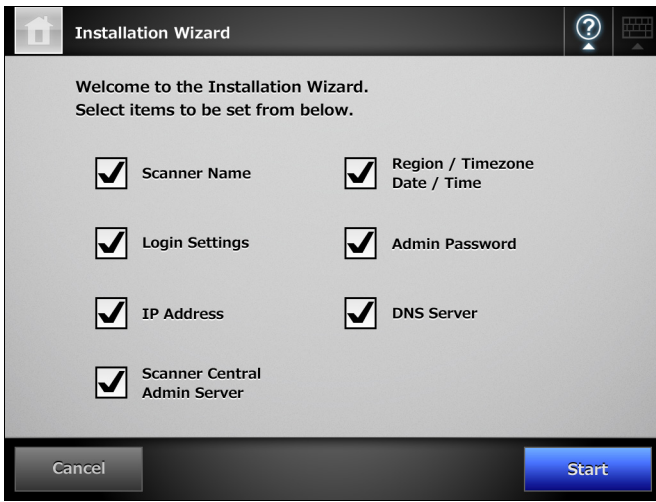

To open Help, press .



6. Set the scanner name.

On the [Scanner Name] window, specify the scanner name and group or domain for joining the network, and press the [Next] button.

HINT

- To enter characters, press  to show the on-screen keyboard. The button turns into  when the on-screen keyboard is shown.
- After entering characters, press  to hide the on-screen keyboard.
- The button turns into  on a window with no items requiring characters to be entered.
- For the on-screen keyboard layout, refer to the Operator's Guide.

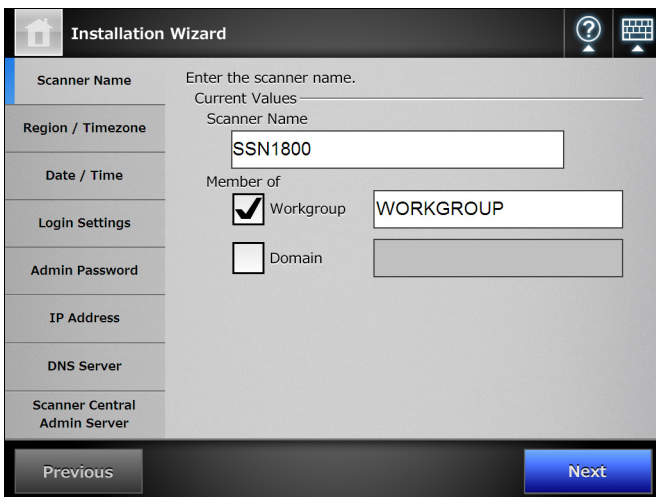

7. Set the region/timezone.

On the [Region / Timezone] window, select the region/timezone and whether to apply daylight saving time, and press the [Next] button.



8. Set the date and time.

On the [Date / Time] window, specify the date format and the current date and time, and press the [Next] button.



9. Specify the login settings.

On the [Login Settings] window, specify the settings for login, and press the [Next] button.



10. Change the admin password.

On the [Admin Password] window, specify the administrator password, and press the [Next] button. The default value for the [Current Password] is "password".

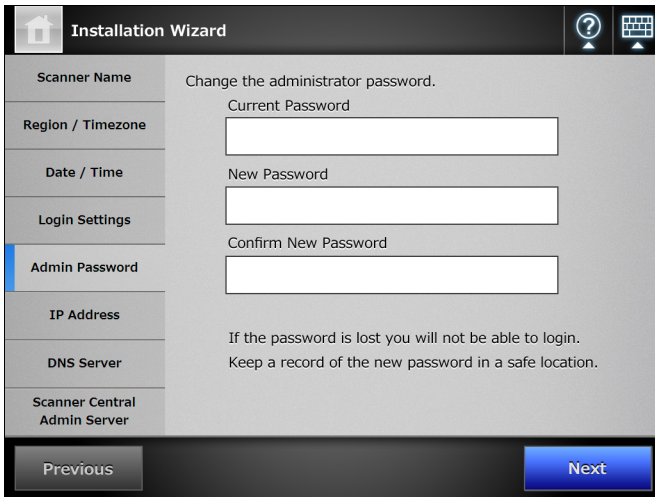

11. Set the scanner's IP address.

On the [IP Address] window, set the scanner's IP address, and press the [Next] button.

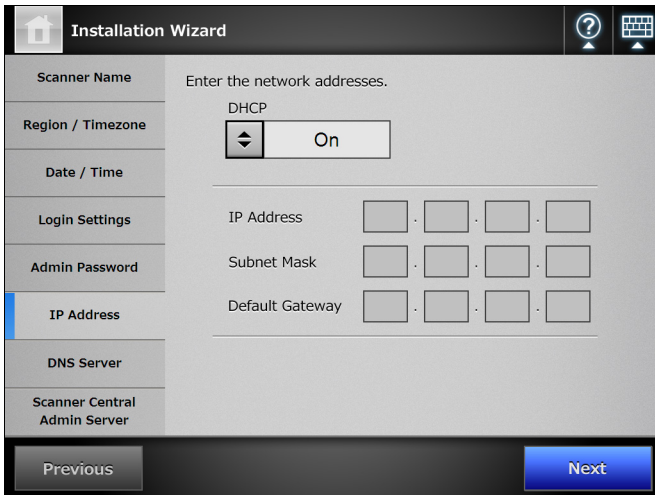

ATTENTION

If DHCP is not used, do not use an IP address that already exists in the network. If the same IP address as the specified IP address already exists, an error occurs.

12. Set the DNS server.

On the [DNS Server] window, set the IP address for the DNS server, and press the [Next] button.

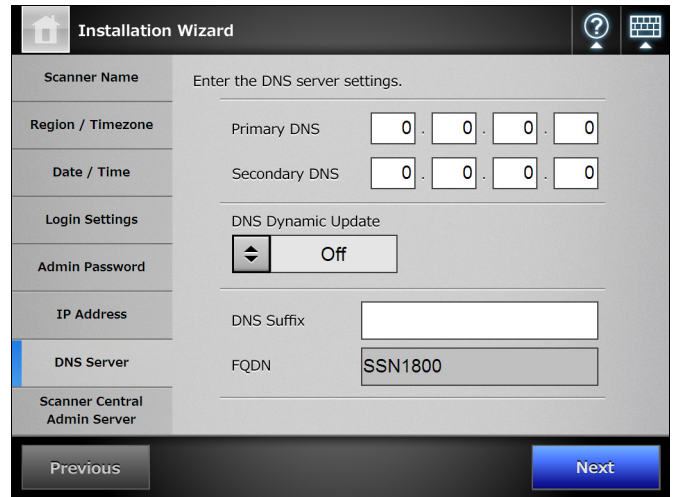

HINT

If the scanner is not connected to the network, the FQDN may not be displayed correctly.

13. Set the Central Admin Server.

On the [Scanner Central Admin Server] window, set whether to enable the Central Admin Server and the Central Admin Server settings, and press the [Finish] button.

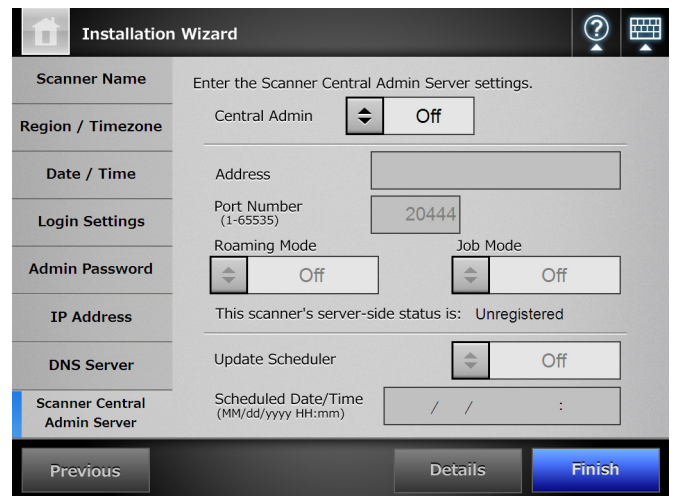

14. Confirm the configured settings.

On the settings confirmation window of the installation wizard, confirm the configured basic settings, and press the [OK] button.

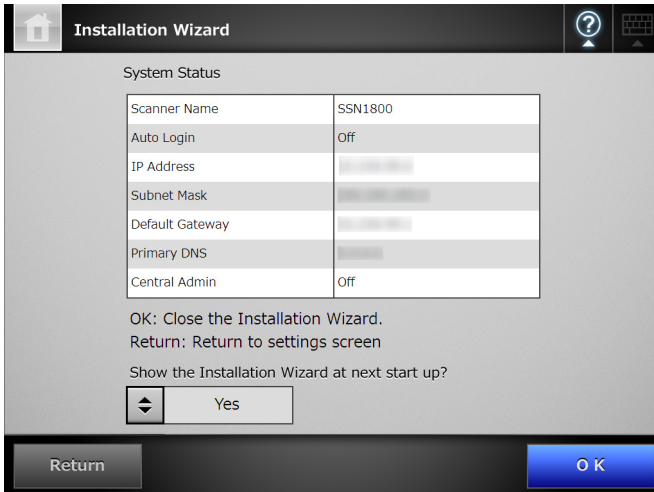

⇒ The wizard finishes and the login window appears.

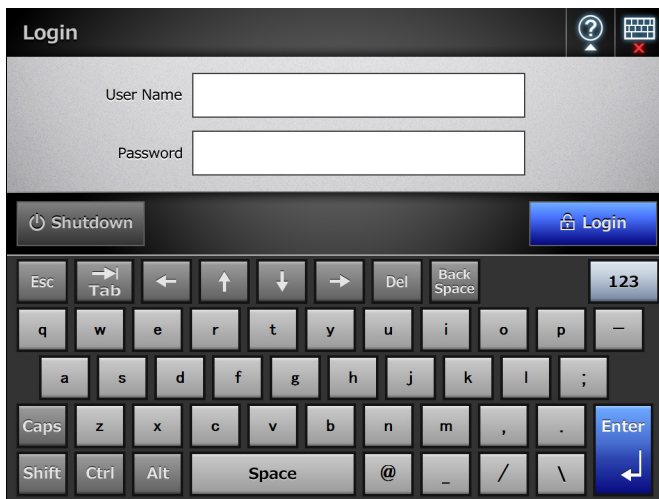

HINT

- When the scanner name or domain name has been changed, the scanner is restarted.
- If you select [No] for [Show the Installation Wizard at next start up?], the [Installation Wizard] window does not appear immediately after the next scanner startup.

This concludes the scanner basic settings procedure.

HINT

The scanner basic settings can be changed by:

- Changing the settings on the [Installation Wizard] window
You can display the [Installation Wizard] window by pressing the [Installation Wizard] button on the [Admin Settings] window that is displayed by pressing  on the [Admin Menu] window.
- Changing the settings for [System Settings] or [Network Settings] on the [Admin Menu] window

For details about how to show the [Admin Menu] window, refer to "Chapter 4 Checking the Network Connection" (page 16).

Chapter 4 Checking the Network Connection

This section describes how to check the status of the network connection.

The network connection can be checked by performing a ping test from [Admin Menu].

1. Log in to the scanner with the user name and password of the administrator.

Enter "admin" for [User Name] and the password specified in the basic settings for [Password]. The default password is "password".



⇒ The [Select Mode] window appears.

2. Select the mode and function, and press the [OK] button.

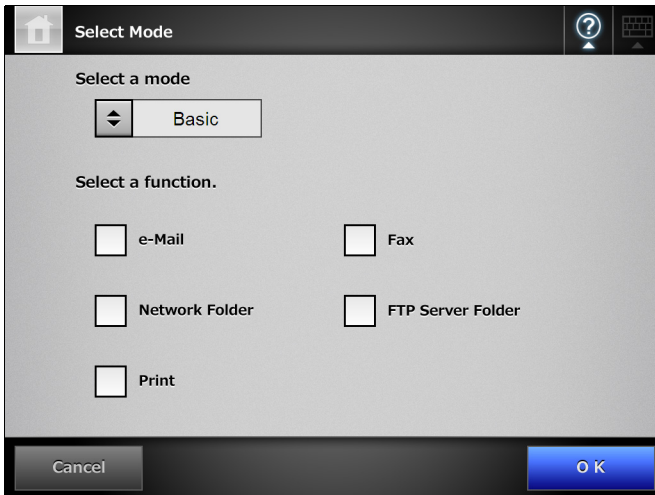

⇒ The [Admin Menu] window appears.

HINT

If you specify settings on the [Select Mode] window, the [Admin Menu] window appears from the next login.

3. Select [Network Settings] → [Basic] → [Ping].

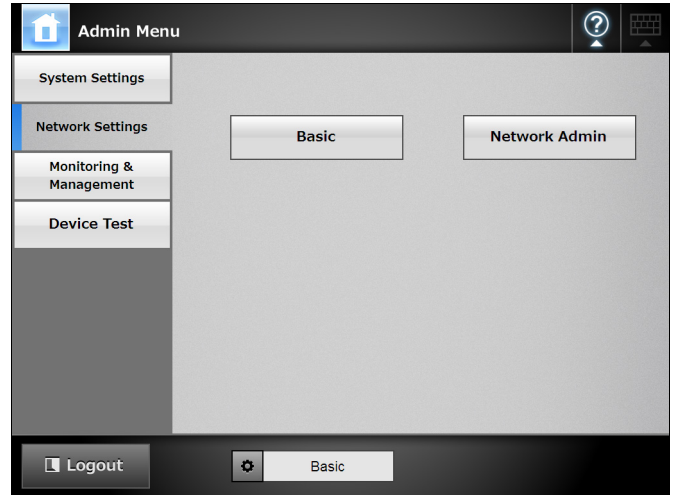

⇒ The [Ping] window appears.

4. Check the status of the network connection.
For [Address], enter the IP address, host name, or FQDN of the computer to be checked.

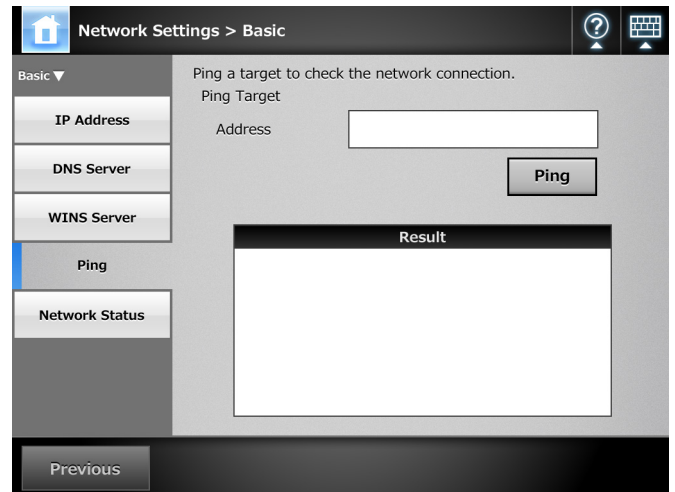

5. Press the [Ping] button.

⇒ A ping test is performed and the results are displayed.

If the result shows "Lost=0 (0% loss)", the network connection is functioning normally.

For any other result, refer to "Checking Basic Network Operation with a Ping Test" (page 18).

6. Press .

⇒ The [Admin Menu] window appears.

7. Press the [Logout] button to log out of the scanner.

Chapter 5 Downloading the Manual

For this scanner, the Operator's Guide (PDF), which contains information about scanner settings, administration, and operations, is provided in addition with this manual. Read it when using the scanner. Use Adobe Reader (*) to view the Operator's Guide.

*: Adobe Reader can be downloaded from the following site.

<http://www.adobe.com/>

This section describes how to download the manual.

1. Specify the scanner name or IP address as the URL using the Web browser (*1) of the computer to which the manual is to be downloaded.

http://scanner_name_or_IP_address/

⇒ The Login window appears.

*1: For this product, use one of the following Web browsers:

- Internet Explorer 6.0 (Service Pack 2 or later) (*2)
- Internet Explorer 7 (*2)
- Internet Explorer 8 (*2)
- Internet Explorer 9 (*2)
- Internet Explorer 10 (*2)

*2: Apply the latest security updates. If they are not applied, you may not be able to download certain manuals. For Windows XP, the security update "KB933566" must be applied to Internet Explorer. If download operations are not possible, clear the [Do not save encrypted pages to disk] check box on [Advanced] of [Internet Options] in Internet Explorer, and then try downloading again.

If the Web browser is Internet Explorer 10, configure [Compatibility View settings] so that the specified URL is displayed in compatibility view.

2. Click the [Operator's Guide] button.

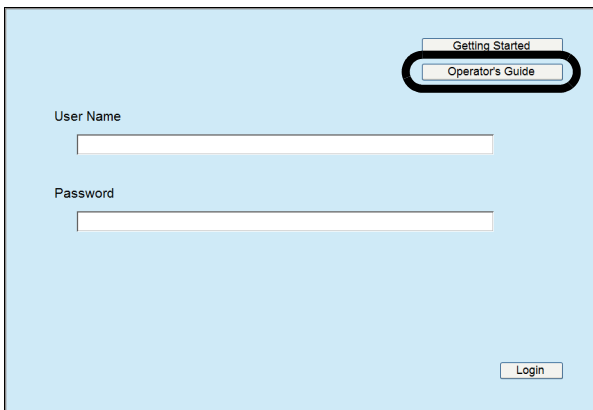

⇒ The [File Download] dialog box appears.

3. Click the [Save] button.

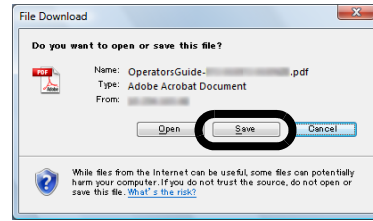

⇒ The [Save As] dialog box appears.

ATTENTION

If Adobe Reader is not installed, and the [Open] button is pressed, a connection error occurs. To open the file with the [Open] button, install Adobe Reader, and then perform steps 1 to 3 again.

4. Select a folder, and click the [Save] button.

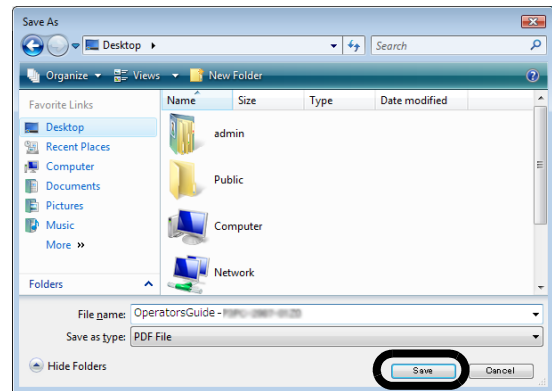

⇒ The manual is downloaded and saved in the specified folder.

Appendix A Troubleshooting

A.1 Network Connection Troubleshooting

■ Checking Basic Network Operation with a Ping Test

The network connection may be checked by performing a ping test. For more details on how to perform a ping test, refer to "Chapter 4 Checking the Network Connection" (page 16).

Check the ping results, and try the following:

**[Ping statistics] shows
"Lost=4 (100% loss)"**

■ Details

Communication with the device that is specified as the ping target is unavailable.

■ Action

- The setting of the ping target may be invalid. Check that the ping target IP address, host name, or FQDN is correct.
- The network transmission mode may differ from the connection target. On the [Network Status] window, change [Link speed / Duplex mode] from [Auto-Negotiation] to a fixed mode. This can be changed as follows:
 1. Select [Network Settings] → [Basic] → [Network Status].
⇒The [Network Status] window appears.
 2. Select a fixed link speed/duplex mode for [Link Speed/Duplex Mode].
 3. Press the [OK] button.
- If there are no problems with the ping target setting and the network transmission mode, refer to "Failure to Connect to a Server Using Its IP Address" (page 19) for further solutions.

**[Ping statistics] shows
"Lost=N (1 to 99% loss)"**

■ Details

Communication with the device specified as the ping target is unstable.

■ Action

- There may be a quality problem with the LAN cable. Replace the LAN cable and try again.
- The network transmission mode may differ from the connection target. On the [Network Status] window, change [Link speed / Duplex mode] from [Auto-Negotiation] to a fixed mode. This can be changed as follows:
 1. Select [Network Settings] → [Basic] → [Network Status].
⇒The [Network Status] window appears.
 2. Select a fixed link speed/duplex mode for [Link Speed/Duplex Mode].
 3. Press the [OK] button.

"Hardware error."

■ Details

There may be problems in the hardware transmission path. For example, the LAN cable may have become disconnected during the ping test.

■ Action

Check the status of the LAN cable and try again.

**"Ping request could not find host
xxxxxxx. Please check the name and
try again."**

■ Details

The name-resolution or address-resolution for the device specified as the ping target may have failed.

■ Action

- Check that the ping target host name or FQDN is correct.
- Check that the DNS server or WINS server settings are correct.
- If the ping target host name or FQDN is correct, refer to "Failure to Connect to a Server Using Its Host Name or FQDN" (page 20) for further solutions.

■ Failure to Connect to a Server Using Its IP Address

If a server cannot be connected to by using its IP address, or if a scanner does not respond to a ping test by specifying its IP address, try the following:

Connection error between the server and scanner. Or there is a problem with the LAN cable.

■ Action

Check that the LAN cable is connected to both the scanner and server correctly.

If the server is connected using a LAN cable (straight type), in case Auto MDI/MDI-X (automatic selection) is not supported, a LAN cable (crossover type), switch, or router is required between the scanner and server.

If this is not the case, the LAN cable may be faulty. Use a LAN cable that functions normally and try again.

IP address or subnet mask is invalid.

■ Action

On the [IP Address] window, check that the IP address or subnet mask settings are correct.

The [IP Address] window can be displayed as follows:

1. Select [Network Settings] → [Basic] → [IP Address].

When using DHCP, the DHCP server does not operate normally. Or there is a problem with the DHCP server settings.

■ Action

If using DHCP, on the [Network Status] window, check that IP address, subnet mask, and default gateway settings are all correct.

If these settings are not correct, the DHCP server may not operate normally, or the DHCP server may not assign valid IP addresses because of restricted number of leases or MAC address validation.

Check the DHCP server connection status and the details of the server settings.

The [Network Status] window can be displayed as follows:

1. Select [Network Settings] → [Basic] → [Network Status].

Another host or communication device is connected using the same IP address as the scanner.

■ Action

If the same IP address has already been used by another host or communication device, then even if the other device has been given a different IP address the server may not recognize the scanner's "duplicate" IP address until it is rebooted. Restart the server.

If a duplicate IP address connection from another host or communication device exists on a LAN, both it will be unusable.

If a duplicate IP address connection from another host or communication device exists, pull out its LAN cable and restart the server.

Access is denied due to the establishment of a firewall between the server and the scanner.

■ Action

If a firewall is established between the server and the scanner, check that it is not set to deny access to the network.

Link speed/duplex mode for the network differs between the scanner and server. Or the server does not support automatic negotiation.

■ Action

Link speed/duplex mode for the network of the scanner is set to the default setting [Auto-Negotiation].

On the [Network Status] window, match the scanner and server's network link speed/duplex mode settings. If the problem persists in spite of having set both the scanner and server's network link speed/duplex settings to [Auto-Negotiation], select something other than [Auto-Negotiation] and check again.

On the [Network Status] window, change [Link speed/Duplex Mode] from [Auto-Negotiation] to a fixed mode. This can be changed as follows:

1. Select [Network Settings] → [Basic] → [Network Status].
⇒ The [Network Status] window appears.
2. Select a fixed link speed/duplex mode for [Link Speed/Duplex Mode].
3. Press the [OK] button.

■ Failure to Connect to a Server Using Its Host Name or FQDN

If the scanner cannot connect to a server by specifying its host name or FQDN, or if a server does not respond to a ping test by specifying its host name or FQDN, try the following:

Same as in "Failure to Connect to a Server Using Its IP Address" (page 19).

■ Action

Check if a network connection is possible by trying the same solution for "Failure to Connect to a Server Using Its IP Address" (page 19).

The scanner's DNS server or WINS server settings are invalid.

■ Action

Check that the DNS and WINS server settings are correct.

The DNS or WINS server does not operate normally. Or an error occurred on the network path to the DNS or WINS server.

■ Action

Ping the DNS or WINS server to check that they are functioning normally.
If the DNS or WINS server is not functioning, request the network administrator to check its status.

■ Failure to Access the Scanner Using a Web Browser, Admin Tool, or Central Admin Server

If access is not possible when attempting to connect to the scanner using a Web browser, the Admin Tool, or the Central Admin Server, or when attempting to connect to the Central Admin Server from the Central Admin Console, try the following:

Same as in "Failure to Connect to a Server Using Its IP Address" (page 19).

■ Action

Check if a network connection is possible by trying the same solution for "Failure to Connect to a Server Using Its IP Address" (page 19).

The DNS or WINS server does not operate normally. Or the scanner name is not registered in the DNS or WINS server.

■ Action

Specify the IP address and check the connection.
If it is possible to connect the scanner using the Admin Tool with a specified IP address, specify the scanner's IP address in the DNS or WINS server.
Check the DNS or WINS server settings on the Web browser and Admin Tool.

A misconfigured firewall between the scanner and the computer installed with the Web browser or Admin Tool (connected via LAN) is denying access with the HTTP/HTTPS protocol.

■ Action

If there is a firewall between the scanner and the computer installed with the Web browser or Admin Tool, check that it is not set to deny access to the network.

The URL of the target scanner is not registered as a trusted site.

■ Action

Set the scanner URL as a trusted site for Internet Explorer.

1. In Internet Explorer, select the [Tools] menu → [Internet Options].
2. On the [Security] tab, select [Trusted sites] and press the [Sites] button.
3. Enter the URL of the scanner in the [Add this website to the zone] field, and press the [Add] button.

In Internet Explorer, the security level for the target zone is set to [High] on the [Security] tab in the [Tools] menu - [Internet Options]. In [Custom Level], [Prompt] or [Disable] is set for [Active scripting] under [Scripting] in the [Settings] area.

■ Action

When connecting using the scanner name, the connection will be an intranet connection. When connecting using an IP address, it will be an internet connection.

Try the following settings for the corresponding zone.

1. In Internet Explorer, select the [Tools] menu → [Internet Options].
2. Enable [Active scripting] in either of the following ways:
 - On the [Security] tab, click the [Default level] button to set [Security level for this zone] to [Medium].
 - On the [Security] tab, click the [Custom level] button to set to [Enable] for [Active scripting] under [Scripting] in the [Settings] area.
3. If connecting via the Internet zone, on the [Privacy] tab, set the level to [Medium High] or below.
4. Delete all temporary internet files with either of the following methods.
 - For Internet Explorer 6.0 (Service Pack 2 or later)
On the [General] tab, click the [Delete Files] button for [Temporary Internet files].
 - For Internet Explorer 7
On the [General] tab, click the [Delete] button for [Browsing history], and click the [Delete files] button for [Temporary Internet Files].
 - For Internet Explorer 8 or Internet Explorer 9
On the [General] tab, click the [Delete] button for [Browsing history], select the [Temporary Internet files] check box, and click the [Delete] button.
 - For Internet Explorer 10
On the [General] tab, click the [Delete] button for [Browsing history], select the [Temporary Internet files and website files] check box, and click the [Delete] button.

The scanner is in standby mode.

■ Action

Press the power button to start the scanner.

A proxy server is being used.

■ Action

Set the proxy server not to be used.

1. In Internet Explorer, select the [Tools] menu → [Internet Options].
2. Press the [LAN settings] button on the [Connections] tab.
3. Clear the [Use a proxy server for your LAN (These settings will not apply to dial-up or VPN connections)] check box.

There is an error with the connection protocol setting.

■ Action

Check if SSL is enabled on the [Admin Connection] window.

The [Admin Connection] window can be displayed as follows:

1. Select [Network Settings] → [Network Admin] → [Admin Connection].

There is an error with the port number setting.

■ Action

Check the specified port number on the [Admin Connection] window.

The [Admin Connection] window can be displayed as follows:

1. Select [Network Settings] → [Network Admin] → [Admin Connection].

In Internet Explorer, [Tools] menu - [Internet Options] - [Advanced] tab, the [Use SSL 3.0] check box under [Security] in the [Settings] area is not selected.

■ Action

1. In Internet Explorer, select the [Tools] menu → [Internet Options].
2. On the [Advanced] tab, select the [Use SSL 3.0] check box under [Security] in the [Settings] area.

A.2 Power Troubleshooting

Scanner cannot be turned on.

■ Check item

Has the power button been pressed?

■ Action

Press the power button.

■ Check item

Are the AC cable and AC adapter properly connected to the scanner?

■ Action

- Connect the AC cable and the AC adapter properly.
- Disconnect power cable from the scanner to turn off the scanner, and connect the cable again. After turning the power off, wait for at least 10 seconds before turning the power back on again.
If the problem persists even after taking the above mentioned actions, contact your FUJITSU scanner dealer or an authorized FUJITSU scanner service provider.

A.3 Login Troubleshooting

Cannot login with administrator password.

■ Check item

Was the Caps Lock on when the password was entered?

■ Action

Turn off the Caps Lock and try logging in again.
If the password has been lost or forgotten, contact your FUJITSU scanner dealer or an authorized FUJITSU scanner service provider.

A.4 Contact for Inquiries

If a solution to your problem cannot be found in the above troubleshooting list, refer to the following web page:

<http://scansnap.fujitsu.com/g-support/en/index.html>

If the solution to your problem cannot be found on the above web page, refer to the contact information for your Fujitsu office on the following web page:

<http://imagescanner.fujitsu.com/warranty.html>

■ Contact for purchasing the Consumable, Cleaning Materials

<http://scansnap.fujitsu.com/>

Copyright

NetAdvantage

Copyright© 2000-2010 Infragistics, Inc.

LEADTOOLS for .NET

Copyright © 2005 LEAD Technologies, Inc.

WinPcap

Copyright © 1999 - 2005 NetGroup, Politecnico di Torino (Italy).

Copyright © 2005 - 2010 CACE Technologies, Davis (California).

All rights reserved.

Redistribution and use in source and binary forms, with or without modification, are permitted provided that the following conditions are met:

1. Redistributions of source code must retain the above copyright notice, this list of conditions and the following disclaimer.
2. Redistributions in binary form must reproduce the above copyright notice, this list of conditions and the following disclaimer in the documentation and/or other materials provided with the distribution.
3. Neither the name of the Politecnico di Torino, CACE Technologies nor the names of its contributors may be used to endorse or promote products derived from this software without specific prior written permission.

THIS SOFTWARE IS PROVIDED BY THE COPYRIGHT HOLDERS AND CONTRIBUTORS "AS IS" AND ANY EXPRESS OR IMPLIED WARRANTIES, INCLUDING, BUT NOT LIMITED TO, THE IMPLIED WARRANTIES OF MERCHANTABILITY AND FITNESS FOR A PARTICULAR PURPOSE ARE DISCLAIMED. IN NO EVENT SHALL THE COPYRIGHT OWNER OR CONTRIBUTORS BE LIABLE FOR ANY DIRECT, INDIRECT, INCIDENTAL, SPECIAL, EXEMPLARY, OR CONSEQUENTIAL DAMAGES (INCLUDING, BUT NOT LIMITED TO, PROCUREMENT OF SUBSTITUTE GOODS OR SERVICES; LOSS OF USE, DATA, OR PROFITS; OR BUSINESS INTERRUPTION) HOWEVER CAUSED AND ON ANY THEORY OF LIABILITY, WHETHER IN CONTRACT, STRICT LIABILITY, OR TORT (INCLUDING NEGLIGENCE OR OTHERWISE) ARISING IN ANY WAY OUT OF THE USE OF THIS SOFTWARE, EVEN IF ADVISED OF THE POSSIBILITY OF SUCH DAMAGE.

This product includes software developed by the University of California, Lawrence Berkeley Laboratory and its contributors.

This product includes software developed by the Kungliga Tekniska Hogskolan and its contributors.

This product includes software developed by Yen Yen Lim and North Dakota State University.

Portions Copyright © 1990, 1991, 1992, 1993, 1994, 1995, 1996, 1997 The Regents of the University of California.

All rights reserved.

Redistribution and use in source and binary forms, with or without modification, are permitted provided that the following conditions are met:

1. Redistributions of source code must retain the above copyright notice, this list of conditions and the following disclaimer.
2. Redistributions in binary form must reproduce the above copyright notice, this list of conditions and the following disclaimer in the documentation and/or other materials provided with the distribution.
3. All advertising materials mentioning features or use of this software must display the following acknowledgement: "This product includes software developed by the University of California, Berkeley and its contributors."
4. Neither the name of the University nor the names of its contributors may be used to endorse or promote products derived from this software without specific prior written permission.

THIS SOFTWARE IS PROVIDED BY THE INSTITUTE AND CONTRIBUTORS "AS IS" AND ANY EXPRESS OR IMPLIED WARRANTIES, INCLUDING, BUT NOT LIMITED TO, THE IMPLIED WARRANTIES OF MERCHANTABILITY AND FITNESS FOR A PARTICULAR PURPOSE ARE DISCLAIMED. IN NO EVENT SHALL THE REGENTS OR CONTRIBUTORS BE LIABLE FOR ANY DIRECT, INDIRECT, INCIDENTAL, SPECIAL, EXEMPLARY, OR CONSEQUENTIAL DAMAGES (INCLUDING, BUT NOT LIMITED TO, PROCUREMENT OF SUBSTITUTE GOODS OR SERVICES; LOSS OF USE, DATA, OR PROFITS; OR BUSINESS INTERRUPTION) HOWEVER CAUSED AND ON ANY THEORY OF LIABILITY, WHETHER IN CONTRACT, STRICT LIABILITY, OR TORT (INCLUDING NEGLIGENCE OR OTHERWISE) ARISING IN ANY WAY OUT OF THE USE OF THIS SOFTWARE, EVEN IF ADVISED OF THE POSSIBILITY OF SUCH DAMAGE.

Portions Copyright © 1983 Regents of the University of California. All rights reserved.

Redistribution and use in source and binary forms are permitted provided that the above copyright notice and this paragraph are duplicated in all such forms and that any documentation, advertising materials, and other materials related to such distribution and use acknowledge that the software was developed by the University of California, Berkeley. The name of the University may not be used to endorse or promote products derived from this software without specific prior written permission.

THIS SOFTWARE IS PROVIDED "AS IS" AND WITHOUT ANY EXPRESS OR IMPLIED WARRANTIES, INCLUDING, WITHOUT LIMITATION, THE IMPLIED WARRANTIES OF MERCHANTABILITY AND FITNESS FOR A PARTICULAR PURPOSE.

Portions Copyright © 1995, 1996, 1997 Kungliga Tekniska Hogskolan (Royal Institute of Technology, Stockholm, Sweden).

All rights reserved.

Redistribution and use in source and binary forms, with or without modification, are permitted provided that the following conditions are met:

1. Redistributions of source code must retain the above copyright notice, this list of conditions and the following disclaimer.
2. Redistributions in binary form must reproduce the above copyright notice, this list of conditions and the following disclaimer in the documentation and/or other materials provided with the distribution.
3. All advertising materials mentioning features or use of this software must display the following acknowledgement: "This product includes software developed by the Kungliga Tekniska Hogskolan and its contributors."
4. Neither the name of the University nor the names of its contributors may be used to endorse or promote products derived from this software without specific prior written permission.

THIS SOFTWARE IS PROVIDED BY THE INSTITUTE AND CONTRIBUTORS "AS IS" AND ANY EXPRESS OR IMPLIED WARRANTIES, INCLUDING, BUT NOT LIMITED TO, THE IMPLIED WARRANTIES OF MERCHANTABILITY AND FITNESS FOR A PARTICULAR PURPOSE ARE DISCLAIMED. IN NO EVENT SHALL THE INSTITUTE OR CONTRIBUTORS BE LIABLE FOR ANY DIRECT, INDIRECT, INCIDENTAL, SPECIAL, EXEMPLARY, OR CONSEQUENTIAL DAMAGES (INCLUDING, BUT NOT LIMITED TO, PROCUREMENT OF SUBSTITUTE GOODS OR SERVICES; LOSS OF USE, DATA, OR PROFITS; OR BUSINESS INTERRUPTION) HOWEVER CAUSED AND ON ANY THEORY OF LIABILITY, WHETHER IN CONTRACT, STRICT LIABILITY, OR TORT (INCLUDING NEGLIGENCE OR OTHERWISE) ARISING IN ANY WAY OUT OF THE USE OF THIS SOFTWARE, EVEN IF ADVISED OF THE POSSIBILITY OF SUCH DAMAGE.

Portions Copyright © 1997 Yen Yen Lim and North Dakota State University. All rights reserved.

Redistribution and use in source and binary forms, with or without modification, are permitted provided that the following conditions are met:

1. Redistributions of source code must retain the above copyright notice, this list of conditions and the following disclaimer.
2. Redistributions in binary form must reproduce the above copyright notice, this list of conditions and the following disclaimer in the documentation and/or other materials provided with the distribution.
3. All advertising materials mentioning features or use of this software must display the following acknowledgement: "This product includes software developed by Yen Yen Lim and North Dakota State University"
4. The name of the author may not be used to endorse or promote products derived from this software without specific prior written permission.

THIS SOFTWARE IS PROVIDED BY THE AUTHOR "AS IS" AND ANY EXPRESS OR IMPLIED WARRANTIES, INCLUDING, BUT NOT LIMITED TO, THE IMPLIED WARRANTIES OF MERCHANTABILITY AND FITNESS FOR A PARTICULAR PURPOSE ARE DISCLAIMED. IN NO EVENT SHALL THE AUTHOR BE LIABLE FOR ANY DIRECT, INDIRECT, INCIDENTAL, SPECIAL, EXEMPLARY, OR CONSEQUENTIAL DAMAGES (INCLUDING, BUT NOT LIMITED TO, PROCUREMENT OF SUBSTITUTE GOODS OR SERVICES; LOSS OF USE, DATA, OR PROFITS; OR BUSINESS INTERRUPTION) HOWEVER CAUSED AND ON ANY THEORY OF LIABILITY, WHETHER IN CONTRACT, STRICT LIABILITY, OR TORT (INCLUDING NEGLIGENCE OR OTHERWISE) ARISING IN ANY WAY OUT OF THE USE OF THIS SOFTWARE, EVEN IF ADVISED OF THE POSSIBILITY OF SUCH DAMAGE.

Portions Copyright © 1993 by Digital Equipment Corporation.

Permission to use, copy, modify, and distribute this software for any purpose with or without fee is hereby granted, provided that the above copyright notice and this permission notice appear in all copies, and that the name of Digital Equipment Corporation not be used in advertising or publicity pertaining to distribution of the document or software without specific, written prior permission.

THE SOFTWARE IS PROVIDED "AS IS" AND DIGITAL EQUIPMENT CORP. DISCLAIMS ALL WARRANTIES WITH REGARD TO THIS SOFTWARE, INCLUDING ALL IMPLIED WARRANTIES OF MERCHANTABILITY AND FITNESS. IN NO EVENT SHALL DIGITAL EQUIPMENT CORPORATION BE LIABLE FOR ANY SPECIAL, DIRECT, INDIRECT, OR CONSEQUENTIAL DAMAGES OR ANY DAMAGES WHATSOEVER RESULTING FROM LOSS OF USE, DATA OR PROFITS, WHETHER IN AN ACTION OF CONTRACT, NEGLIGENCE OR OTHER TORTIOUS ACTION, ARISING OUT OF OR IN CONNECTION WITH THE USE OR PERFORMANCE OF THIS SOFTWARE.

Portions Copyright © 1995, 1996, 1997, 1998, and 1999 WIDE Project. All rights reserved.

Redistribution and use in source and binary forms, with or without modification, are permitted provided that the following conditions are met:

1. Redistributions of source code must retain the above copyright notice, this list of conditions and the following disclaimer.
2. Redistributions in binary form must reproduce the above copyright notice, this list of conditions and the following disclaimer in the documentation and/or other materials provided with the distribution.
3. Neither the name of the project nor the names of its contributors may be used to endorse or promote products derived from this software without specific prior written permission.

THIS SOFTWARE IS PROVIDED BY THE PROJECT AND CONTRIBUTORS "AS IS" AND ANY EXPRESS OR IMPLIED WARRANTIES, INCLUDING, BUT NOT LIMITED TO, THE IMPLIED WARRANTIES OF MERCHANTABILITY AND FITNESS FOR A PARTICULAR PURPOSE ARE DISCLAIMED. IN NO EVENT SHALL THE PROJECT OR CONTRIBUTORS BE LIABLE FOR ANY DIRECT, INDIRECT, INCIDENTAL, SPECIAL, EXEMPLARY, OR CONSEQUENTIAL DAMAGES (INCLUDING, BUT NOT LIMITED TO, PROCUREMENT OF SUBSTITUTE GOODS OR SERVICES; LOSS OF USE, DATA, OR PROFITS; OR BUSINESS INTERRUPTION) HOWEVER CAUSED AND ON ANY THEORY OF LIABILITY, WHETHER IN CONTRACT, STRICT LIABILITY, OR TORT (INCLUDING NEGLIGENCE OR OTHERWISE) ARISING IN ANY WAY OUT OF THE USE OF THIS SOFTWARE, EVEN IF ADVISED OF THE POSSIBILITY OF SUCH DAMAGE.

Portions Copyright © 1996 Juniper Networks, Inc. All rights reserved.

Redistribution and use in source and binary forms, with or without modification, are permitted provided that: (1) source code distributions retain the above copyright notice and this paragraph in its entirety, (2) distributions including binary code include the above copyright notice and this paragraph in its entirety in the documentation or other materials provided with the distribution.

The name of Juniper Networks may not be used to endorse or promote products derived from this software without specific prior written permission.

THIS SOFTWARE IS PROVIDED "AS IS" AND WITHOUT ANY EXPRESS OR IMPLIED WARRANTIES, INCLUDING, WITHOUT LIMITATION, THE IMPLIED WARRANTIES OF MERCHANTABILITY AND FITNESS FOR A PARTICULAR PURPOSE.

Portions Copyright © 2001 Daniel Hartmeier. All rights reserved.

Redistribution and use in source and binary forms, with or without modification, are permitted provided that the following conditions are met:

- Redistributions of source code must retain the above copyright notice, this list of conditions and the following disclaimer.
- Redistributions in binary form must reproduce the above copyright notice, this list of conditions and the following disclaimer in the documentation and/or other materials provided with the distribution.

THIS SOFTWARE IS PROVIDED BY THE COPYRIGHT HOLDERS AND CONTRIBUTOR "AS IS" AND ANY EXPRESS OR IMPLIED WARRANTIES, INCLUDING, BUT NOT LIMITED TO, THE IMPLIED WARRANTIES OF MERCHANTABILITY AND FITNESS FOR A PARTICULAR PURPOSE ARE DISCLAIMED. IN NO EVENT SHALL THE COPYRIGHT HOLDERS OR CONTRIBUTORS BE LIABLE FOR ANY DIRECT, INDIRECT, INCIDENTAL, SPECIAL, EXEMPLARY, OR CONSEQUENTIAL DAMAGES (INCLUDING, BUT NOT LIMITED TO, PROCUREMENT OF SUBSTITUTE GOODS OR SERVICES; LOSS OF USE, DATA, OR PROFITS; OR BUSINESS INTERRUPTION) HOWEVER CAUSED AND ON ANY THEORY OF LIABILITY, WHETHER IN CONTRACT, STRICT LIABILITY, OR TORT (INCLUDING NEGLIGENCE OR OTHERWISE) ARISING IN ANY WAY OUT OF THE USE OF THIS SOFTWARE, EVEN IF ADVISED OF THE POSSIBILITY OF SUCH DAMAGE.

Portions Copyright 1989 by Carnegie Mellon.

Permission to use, copy, modify, and distribute this program for any purpose and without fee is hereby granted, provided that this copyright and permission notice appear on all copies and supporting documentation, the name of Carnegie Mellon not be used in advertising or publicity pertaining to distribution of the program without specific prior permission, and notice be given in supporting documentation that copying and distribution is by permission of Carnegie Mellon and Stanford University. Carnegie Mellon makes no representations about the suitability of this software for any purpose. It is provided "as is" without express or implied warranty.

WinDump

Copyright © 1999 - 2005 NetGroup, Politecnico di Torino (Italy).
Copyright © 2005 - 2006 CACE Technologies, Davis (California).
All rights reserved.

Redistribution and use in source and binary forms, with or without modification, are permitted provided that the following conditions are met:

1. Redistributions of source code must retain the above copyright notice, this list of conditions and the following disclaimer.
2. Redistributions in binary form must reproduce the above copyright notice, this list of conditions and the following disclaimer in the documentation and/or other materials provided with the distribution.
3. Neither the name of the Politecnico di Torino, CACE Technologies nor the names of its contributors may be used to endorse or promote products derived from this software without specific prior written permission.

THIS SOFTWARE IS PROVIDED BY THE COPYRIGHT HOLDERS AND CONTRIBUTORS "AS IS" AND ANY EXPRESS OR IMPLIED WARRANTIES, INCLUDING, BUT NOT LIMITED TO, THE IMPLIED WARRANTIES OF MERCHANTABILITY AND FITNESS FOR A PARTICULAR PURPOSE ARE DISCLAIMED. IN NO EVENT SHALL THE COPYRIGHT OWNER OR CONTRIBUTORS BE LIABLE FOR ANY DIRECT, INDIRECT, INCIDENTAL, SPECIAL, EXEMPLARY, OR CONSEQUENTIAL DAMAGES (INCLUDING, BUT NOT LIMITED TO, PROCUREMENT OF SUBSTITUTE GOODS OR SERVICES; LOSS OF USE, DATA, OR PROFITS; OR BUSINESS INTERRUPTION) HOWEVER CAUSED AND ON ANY THEORY OF LIABILITY, WHETHER IN CONTRACT, STRICT LIABILITY, OR TORT (INCLUDING NEGLIGENCE OR OTHERWISE) ARISING IN ANY WAY OUT OF THE USE OF THIS SOFTWARE, EVEN IF ADVISED OF THE POSSIBILITY OF SUCH DAMAGE.

This product includes software developed by the University of California, Lawrence Berkeley Laboratory and its contributors.

Secure iNetSuite

Copyright© 2008 Dart Communications